

**FAMU/FSU College of Engineering
Department of Mechanical Engineering**



Spring Update

Marine Keel Cooler Optimization Tool

EML 4551C Senior Design



Project Sponsor: Frank Ruggiero - Cummins Inc.

Faculty Advisor: Steven W. Van Sciver, Ph.D.

Submitted to: Nikhil Gupta, Ph.D.

Submission Date: 15 January 2016

Team 3

Melissa Allende ma10k@my.fsu.edu

Grady Beasley gob12@my.fsu.edu

Stanko Gatalj sg11j@my.fsu.edu

James Haga hjh11@my.fsu.edu

Jacob Ross jmr12@my.fsu.edu

Table of Contents

Table of Figures	iii
Table of Tables	iv
Abstract	v
Acknowledgments	vi
1. Introduction	1
2. Problem Definition	3
2.1 Background Research	3
2.2 Problem Statement.....	7
2.3 Project Goal & Objectives.....	7
2.4 Constraints	10
3. Design and Analysis	11
3.1 Software Design	11
3.2 Hardware Design	13
4. Updates and Schedule	16
4.1 Updates	16
4.2 Schedule.....	16
5. Conclusion	18
References	19
Biography	20

Table of Figures

Figure 1. Simple Diagram of a Typical Keel Cooler System.	1
Figure 2. Minimum Keel Cooler Surface Area.....	5
Figure 3. LTA Inlet and Outlet Connections and Pressure Service Ports.....	6
Figure 4. JWAC and LTA cooling system loops.....	6
Figure 5. House of Quality.....	9
Figure 6. Current Specification Sheet.....	12
Figure 7. Flow Chart for the Keel Cooler Optimization Tool	13
Figure 8. Keel Cooler Testing Apparatus	14
Figure 9. Gantt Chart	17

Table of Tables

Table 1. Decision Matrix 11

Abstract

This report defines the project plans, and product specifications for the Marine Keel Cooler Optimization Tool. Cummins Marine is in need of a better tool which would enable the Marine Application Engineers to ensure proper validation of the marine keel cooler. The current tool was developed in the early 1980's and is limited to only steel keel coolers and only provides a pass/fail output to the user. The team is then faced with the creation of a new tool which will not only test the pass/fail cooling capability of the keel cooler but the tool will also be able to calculate box channel, half round and full pipe sections in steel or aluminum. It will evaluate an existing keel cooler system and be able to recommend other sizes which would optimize the cooling per vessel/engine installation. Such tool will allow the Marine Application Engineer to validate the keel cooler not only in extreme conditions but in different climates as well since most commercial vessels will navigate across international waters.

To ensure tool accuracy, research has been conducted to obtain adequate knowledge with regards to keel cooled systems and the design parameters needed to keep in mind. The following report includes an overview of the schedule being followed in order to complete the project. The overall plan, methodology and project approach decided upon by the team will ensure deliverables are met on time and an accurate product is delivered to the sponsor.

Acknowledgements

The team would like to acknowledge our advisor, Dr. Van Sciver for his insight and direction. The team has been given the opportunity to meet with Dr. Van Sciver weekly in order to talk about the science involved as well as the methodology the team should follow when approaching this project. He has provided the insight needed in order to ensure success in the project ventures. The team would also like to acknowledge the Senior Design instructor, Dr. Gupta who also has met with the team weekly to discuss schedule and make sure the team covers the project scope appropriately. The team would also like to extend an acknowledgement to Frank Ruggiero for the opportunity to work on a project for the Marine Application Engineering group as well for the sponsorship and technical support of this project.

1. Introduction

Modern ships and boats rely upon high-powered propulsion systems in order to successfully navigate through their respective environments. The delivered power of engines for typical commercial marine vessels ranges between 230-2700 hp (169-2013 kW)¹. In order for these vessels to function properly, heat must be dissipated effectively in order to achieve the optimal efficiency for sailing conditions.

There are two main types of cooling systems for marine engines; the first is known as a raw water system and the second is known as the freshwater (closed) cooling system. In a raw water system, surrounding water is drawn from the outside of the ship and is circulated through the engine block and then expelled from the exhaust. This is hazardous to the system in both salt- and fresh-water application due to the corrosiveness of salt on the water pump impellers and the risk of foreign contaminants which could lead the system to foul. The engine components risk early failure and may lead to an engine overhaul before the vessel operator's expected to.

The second type of cooling system is known as a closed cooling system. These systems do not employ water as a direct cycling fluid rather, rather piping is used to separate the coolant and the surrounding medium. Some systems function similar to the radiator in automobiles where coolant is pumped through one side of a heat exchanger and raw water is pumped through another

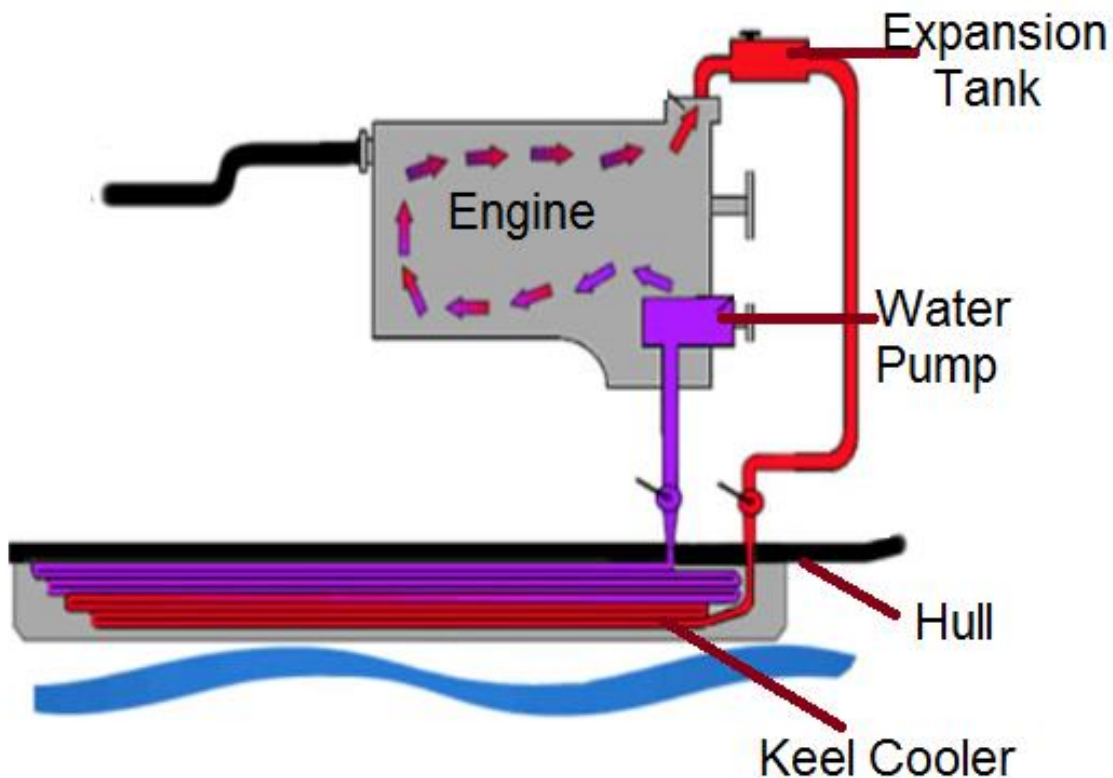

Figure 1: Simple diagram of a typical keel cooler system

in order to dissipate heat. Another type of closed cooling system removes the need for a heat exchanger by employing an external set of pipes which protrude from the bottom of the vessel to exchange heat directly with the surrounding water. Keel coolers operate by taking advantage of the surrounding water as an endless heat sink for a vessel's heat transfer fluid. Due to the risk of fouling from various contaminants contained in the water medium, these coolers typically do not run ocean water directly through the power cycle, but rather exchange heat via convection through external tubing between the engine coolant and the surrounding medium. This process is illustrated in *Figure 1*, explaining just how this process takes place. A pump draws coolant from the thermostat and sends it through an expansion valve, which sends coolant into the keel cooler at the bottom of the vessel. The heated fluid moves through a series of highly conductive pipes which remove the heat via convection with the heat sink. The cooled coolant is finally pumped back into the engine via a cooling pump. This process eliminates the need for a heat exchanger, and other components vital for closed cooling systems.

Cummins Marine is one of the different specialized markets of Cummins Inc. which specializes in the "Marinization" of engines and the design of new components to allow the current Cummins engine line survive in marine applications. Customers often times ask the Application Engineers to ensure the engine selected will work properly with the vessel it is going to be installed in. This includes the sanity check of ensuring that the keel cooler will provide the correct cooling for the engine. These factors are important to consider since the vessel must pass an Installation Quality Assurance Review in order to meet warranty. In order to meet customer's requirements, Cummins Marine makes use of a web-based optimization tool which allows the Application Engineers to predict whether or not a particular keel cooler design will successfully meet the vessels' requirements. The program operates on user-inputted parameters such as keel size, engine power, and temperature range². These values then predict whether the cooler will pass or fail based on extreme operating conditions. Although the tool has been in service for a long time, it has several limitations. The tool only predicts keel cooler systems which are made from steel and does not offer an option to optimize the design. The program lacks feedback and is outdated as a user interface. The goal of the Keel Cooler Optimization Tool Senior Design Project is to create a tool that adds feedback alongside the pass-fail conditions. The program will suggest improvements in the design of the keel cooler based on a thermodynamic analysis. Such improvements can range from material selection, pipe configuration as well as an optimal temperature range of operating conditions. The successful implementation of this tool will result in an increase in company profit and customer satisfaction. With a program which successfully predicts improvements in keel cooler design, boat builders will be able to build the keel coolers with confidence knowing it will be more efficient and optimize the performance of their engine and work in different nautical waters.

To achieve this goal, extensive background research must be conducted on the variables important to the design of a keel cooler. Once the group has a full understanding of the analysis process, the method for creating this tool must be decided upon; this includes the programming language, program structure, user interface and a means for testing the accuracy of the program. The group must show sufficient understanding of the thermal design process and develop a product that is user-friendly, intuitive and provides meaningful feedback to the end user.

2. Project Definition

2.1 Background Research

A current model of this program exists and is used by Cummins. The program is used to evaluate the current and future keel coolers which will be installed in the vessels³. The current system of evaluating the keel coolers is done by looking at the engine which will be installed on the ship, the total heat generated by the engine, design speed of the vessel, maximum water temperature the vessel will face and currently only evaluates keel coolers made out of steel. This current program does not provide the user with suggestions on how to design a more efficient keel cooler and has been in commission since the early 1980's and is in dire need for an update.

Cummins Keel Cooler program was only developed to test keel coolers after production and would only determine as pass or fail given worst case scenarios. The new program will not only determine a pass or fail, it will suggest an optimal keel cooler size, design and material. The program underdevelopment is meant to be easily transferable and shared between users and eventually be converted to a web based program. The new program will most likely ask for the same input parameters as the previous program, but will be more accurate to ensure the keel coolers are properly sized and fitted for the vessels. The ease of evaluation needs to stay constant as well since the easier the program is to use, the more likely it will be utilized. The current design is web based, therefore the new design will need to be converted to a web based system once it is completed.

A keel cooler works as a radiator or heat exchanger attached to hull of the ship. One such textbook which will be referred to for future equations, charts, and tables on heat flow from a high temperature to a low temperature would be "Fundamentals of Thermal fluid Science's". For possibly making suggestions for better keel cooler designs the group would possibly need to suggest the addition of aluminum to the material selection. To do so, material properties would need to be known to allow proper suggestions. The group will possibly be referencing the materials book "Materials Science and Engineering an Introduction".

There is no opposition for this product due to it being geared towards Cummins engines to ensure that installed engines will work properly on the vessels without overheating. This program will be licensed by Cummins for its own use. The only program that would compete with this end product would be the current program the Marine Application group has been utilizing.

Keel cooling utilizes a group of tubes, pipes or channels attached to the outside of the hull below the waterline. Engine coolant is circulated through the keel cooler to remove excess heat. Fabricated keel coolers are manufactured by the boat builder as a part of the hull construction. Structural steel or aluminum shapes are usually used with 0.187 inch [4.8 mm] to 0.500 inch [12.7 mm] wall thickness. These materials must be compatible with materials used in the vessel's hull in order to prevent galvanic corrosion. Fabricated keel coolers must be designed oversized to allow for the decrease in effectiveness which occurs with the formation of rust, scale, pitting and marine growth on the keel cooler. Keel coolers can be sized given the following data from the Engine Data Sheet: Engine Model and Rating, heat rejection, engine coolant flow to keel coolers, coolant type, as well as the design speed of the vessel (in knots). Typical sizing speeds are 1-2 knots for tugboats/push boats and 0.1-1 knots for generator sets.

Fabricated keel coolers can be made from many different materials and type of construction. Most commonly used are steel channel and pipe, although this tool will also allow

calculations for aluminum channel and pips. The shape of the keel cooler is determined by the hull shape and size of the vessel. A fabricated keel cooler is not an efficient heat exchanger and therefore it is much larger in surface area than commercial keel coolers. Keel cooler length formulas for round pipe *Equation 1 (in feet) and 2 (in meters)*, and square channel *Equation 3 (in feet) and 4 (in meters)*. In order to calculate the required length for a half round pipe, one would use *Equation 1* and divide by 2. The “A” used in the formula is the keel cooler area coefficient. Utilizing these formulas the team will be able to calculate the cross sectional area required in order to size the keel cooler, which takes into consideration the channel design type being used, round pipe *Equation 5*, half round pipe *Equation 6* and for square channel *Equation 7*. This is dependent on the design speed of the vessel as well as the maximum raw water temperatures as shown in *Figure 2*. Flow path is also a critical part of the design, since the keel cooler can be sized smaller the more flow paths available. It is also important to note, the program will ask for the length of the vessel in order not to conduct unnecessary size recommendations.

Round Pipe

$$\text{Length (ft)} = \frac{\text{Heat Rejection } \left(\frac{\text{BTU}}{\text{min}}\right) \times "A" \times 3.82}{\text{Pipe I.D. Diameter (in)}} \quad (1)$$

$$\text{Length (m)} = \frac{\text{Heat Rejection (kW)} \times "A" \times 1682}{\text{Pipe I.D. Diameter (mm)}} \quad (2)$$

Note: For half round piping, multiply the calculated length by two.

Square Channel

$$\text{Length (ft)} = \frac{\text{Heat Rejection } \left(\frac{\text{BTU}}{\text{min}}\right) \times "A" \times 12}{\text{Width (in)} + [2 \times \text{Height (in)}]} \quad (3)$$

$$\text{Length (m)} = \frac{\text{Heat Rejection (kW)} \times "A" \times 5288}{\text{Width (mm)} + [2 \times \text{Height (mm)}]} \quad (4)$$

Round Pipe-Area

$$\text{Round Pipe Cross Section Area} = \frac{[\text{Inside Diameter}]^2}{1.27} \quad (5)$$

Half Round Pipe-Area

$$\text{Half Round Pipe Cross Section Area} = \frac{[\text{Inside Diameter}]^2}{2.54} \quad (6)$$

Square Channel-Area

$$\text{Square Channel Cross Section Area} = \text{Inside Dimensions} \times \text{Width} \times \text{Height} \quad (7)$$

Note: Using **inch** dimensions gives **square inch** areas. Using **mm** dimensions gives **square mm** areas.

It is important to keep in mind the coolant velocity inside of the cooler. If the coolant flows through the keel cooler faster than 8 ft/sec [2.5 m/sec] the internal components will deteriorate, causing failure near manifold entrances and exits, elbows and other discontinuities in the coolant flow. Likewise, if the coolant flows through the keel coolers' passages too slowly rust particles or other particulate matter will settle out, choke off the flow and degrade the transfer of heat. In order

to determine the proper flow pattern through the keel cooler, one needs to determine the minimum and maximum expected coolant flow through the keel cooler. This can be obtained from the performance data of the engine water pump. Calculating the difference between the maximum and minimum expected coolant flow and multiply the resultant by $\frac{2}{3}$ and adding $\frac{2}{3}$ will help determine the coolant flow and how to distribute the flow through the keel cooler passages. Then one would divide the coolant flow by the cross-sectional area of one keel-cooler passage to obtain the average velocity. If the average velocity through the keel cooler flow passages is greater than 8 ft/sec [2.5 m/sec], one would arrange the coolant flow in parallel so it would pass through two or more of the keel cooler passages per pass through the keel cooler. If the average velocity through the keel cooler flow passages is less than 2 ft/sec [0.6 m/sec], a keel cooler passage with a smaller cross section would be most adequate. The tool will focus on the three major data inputs for the engine in order to size/validate the keel cooler for the vessel, heat rejection, flow and change in temperature across the pressure ports. There are two 1-1/2 NPT threaded connection provided for the installer to connect to the keel cooler circuit. *Figure 3* shows the inlet and outlet connection points to which the engine connects to the keel cooler via hoses. The pressure service ports is where Marine Application Engineers collect the data readings for pressure testing as well as collect the change in temperature. There are different types of keel cooling layouts, for example the Jacket Water After Cooler (JWAC) and Low Temperature After Cooler (LTA) *Figure 4*.

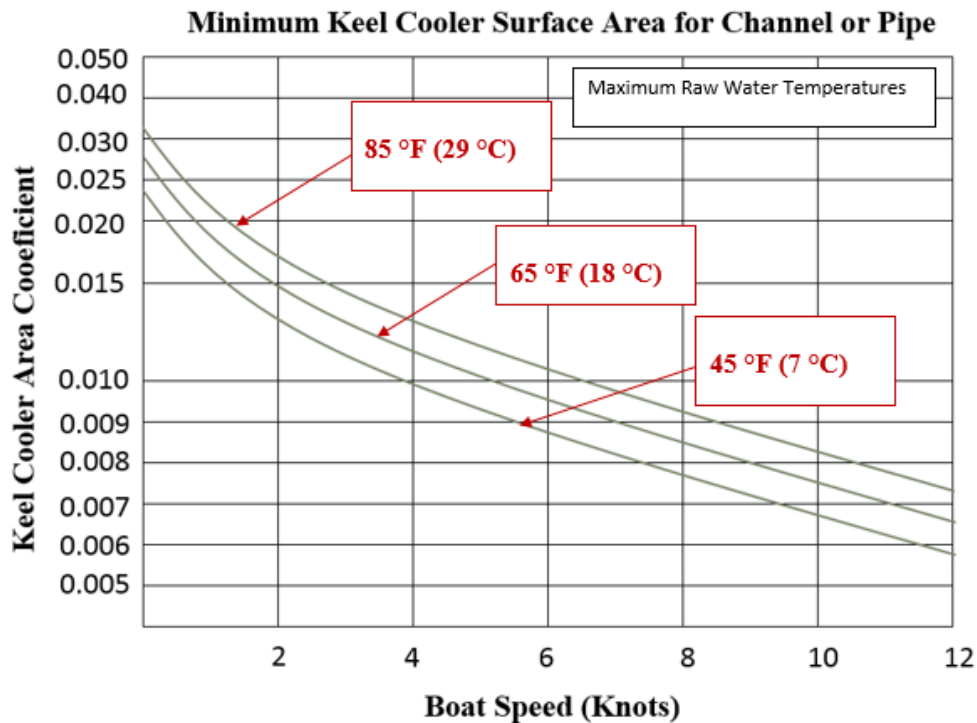

Figure 2: Minimum Keel Cooler Surface Area for Channel or Pipe.

The program will ask the user which type is being utilized in the vessel, such detail is important since the flow of the coolant is affected by the position of the thermostat in each system. For example, in an LTA system the thermostat is before the keel cooler. When the engine coolant is cold, the thermostat is closed and all coolant flows directly to the after cooler and is by-passing the keel cooler. When the thermostat begins to open (depending on the engine the opening temperature will vary) coolant is directed through the keel cooler and is returned back to the thermostat housing where it is mixed with the main flow going through the after cooler. In an installation which is JWAC, the coolant passes through the keel cooler but is waiting for the thermostat to open in order for the coolant to pass through and enter the engine. This is important to take into account when designing the tool, especially if the team were to expand and include calculations for the expansion tank for the after cooler. In such case coolant capacity for the installation would then have to be considered as well.

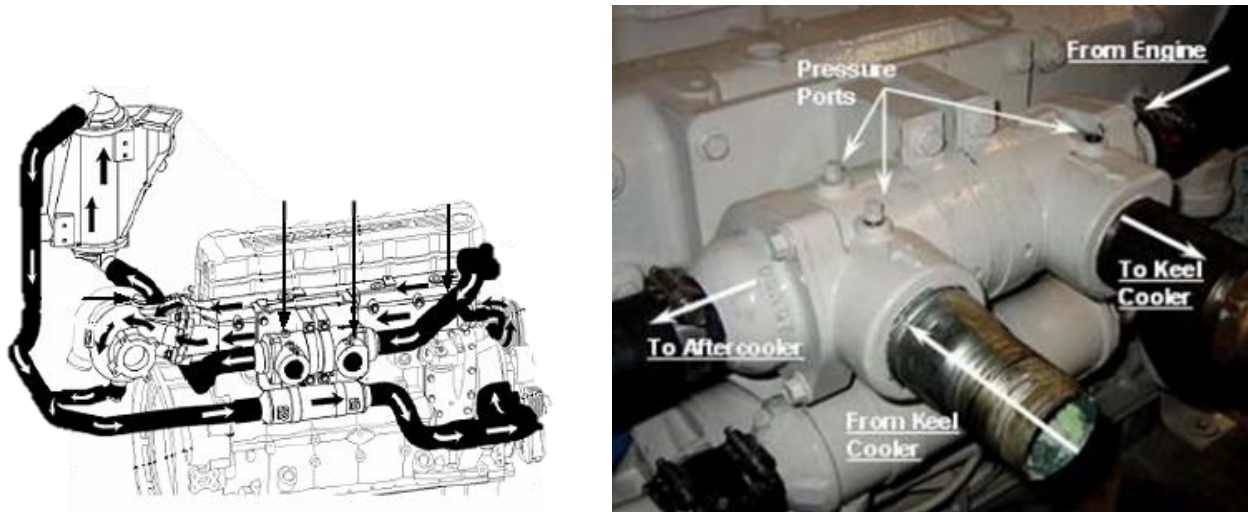

Figure 3. LTA Inlet and outlet connections and pressure service ports on engine

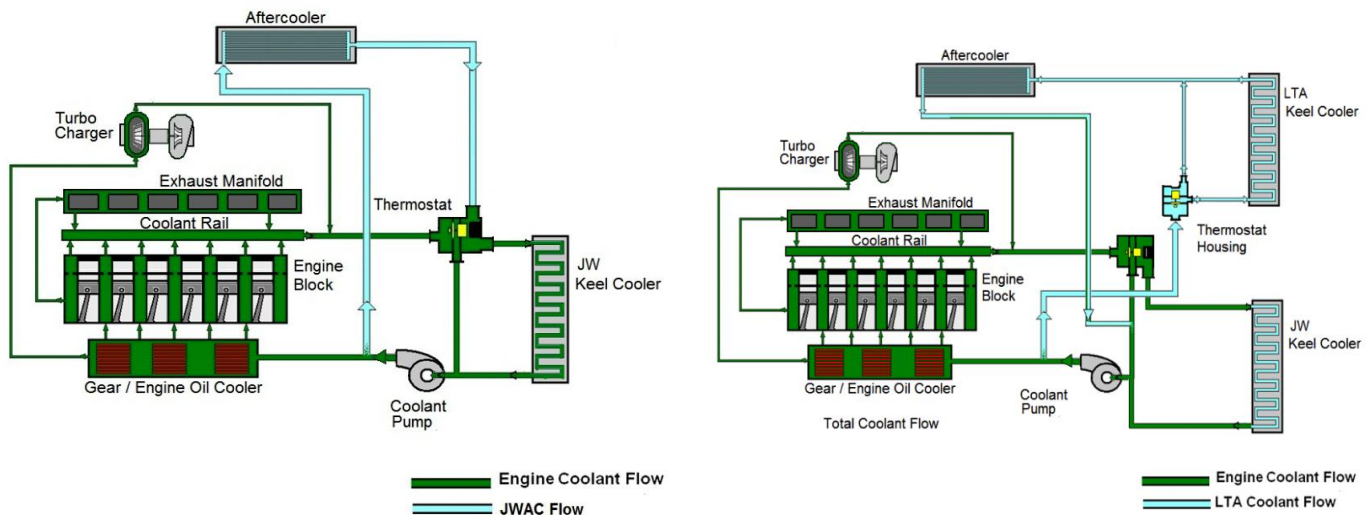

Figure 4. Jacket Water After Cooler system (left) and Low Temperature After Cooler (right)

2.2 Problem Statement

The Senior Design Project for Group 3 for the Marine Keel Cooler Optimization Tool is sponsored by Cummins Marine. The tool currently utilized by the Marine Application Engineers is severely outdated and only returns whether or not the user inputted parameters will result in a passing or failing keel cooler design. The program does not provide any feedback to the designer or operator. This limits the overall design process and does not validate the keel cooler design on the vessel for other nautical water climates and does not evaluate multiple materials which is a necessity for the clients.

Problem Statement for Team 3:

“The current Cummins keel cooler design tool provides no feedback on a particular design and is limited in its capability”

2.3 Project Goal& Objectives

The project should cover all marine engines offered by Cummins, both current production and out of production which will/are installed in keel cooled vessels. The tool is to be used not only to validate the keel cooler system but also suggest the optimal keel cooler design to the boat builder. The tool must be able to calculate and predict how the cooling system will behave under different engine loads and water ambient temperatures. This tool will then be validated through testing on a sea channel constructed by the team and depending on boat builder availability, it will be tested on a current installation.

Project Goal for Team 3:

“Design a more versatile design tool which generates feedback and provides a more user friendly interface”

The team decided that the program delivered to the client will provide customer feedback and will offer ways to increase efficiency in the system. The new layout will allow for more customer focused interface, through a quick and versatile programming language which will allow the tool to be converted into other languages easily.

Project Scope:

- The current design has no customer feedback
- Only provides user an output of “Pass/Fail” on design of keel cooler
- Needs to provide recommendations for design improvement
- The device needs to be able to evaluate the design of the keel cooler through the use of different materials (Currently only evaluates steel)
- Current tool is outdated and not user friendly

Objectives:

- Successfully predicts the heat dissipation, efficiency, as well as the optimal operation temperatures for a particular design
- Suggests useful design alterations that would increase the efficiency of the design
- Validate the keel cooler system in scenarios where the vessel is at low idle or relocated to a different body of water (different ambient water temperature)
- Must be user friendly and intuitive
- Needs to provide results that as accurate as possible
- Be able to evaluate keel cooler designs for more materials than just steel

In the house of quality as seen below in *Figure 5*, the two important inputs are customer characteristics and engineering characteristics. The customer characteristics come from talking to our sponsor and asking what exactly the sponsor would like to see in the new program. These characteristics go in the column on the far left side of the house of quality. The engineering characteristics come from our team brainstorming how to best incorporate the customer characteristics into the new program. These characteristics go across the top of the house of quality.

In the customer priority list is how important the customer thought each customer characteristics is. Inside of the matrix is how well each engineering characteristic correlates with each customer characteristic. A weak correlation is a 1, a medium correlation is a 2 and a strong correlation is a 4. After each box has a correlation number in it, each box is multiplied by the customer priority. Finally each column in the matrix is summed and the largest number is the most important in the design and lowest number is the least important in the design.

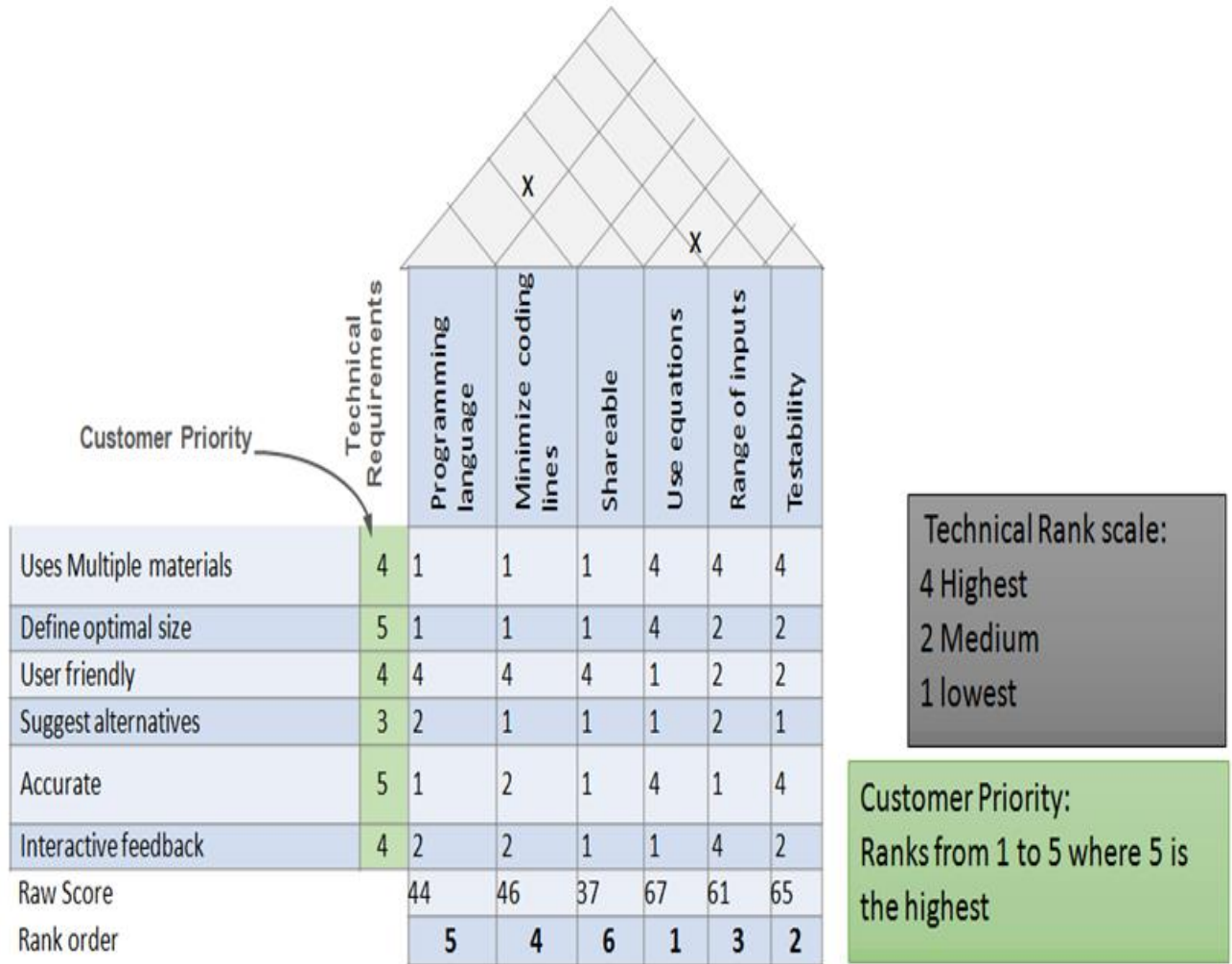

Figure 5. Team 3 House of Quality which helped determine which were the most important factors for the new keel cooler tool

So according to the house of quality, the most important characteristic for our program is the use of equations. For our design this means that the team will need to use more equations that take into account rust, paint, and marine life build up. It also needs to use more equations to account for multiple materials and to provide more customer feedback. The least important factor for our team to take into account is the share ability, the program, since it is electronic, will most likely be easily shared no matter how the program is made.

2.4 Constraints

This project will need to be able to take parameters from the different marine engine models both current production and out of production and be able to calculate the adequate size and cooling needed dependent on the vessel application. With over 15 engines models and each different performance rating available, it is going to be important to find the common variables which can

serve as inputs for the tool. The tool must be able to conduct the test for low and high temperature and pressure ranges to ensure the engine receives adequate cooling under different conditions. Since the tool is to be used by Cummins Distributors and Marine Application Engineers around the world, the tool needs to be accessible through the Cummins Marine website as well as available for download (for when the tool needs to be accessed in areas where there is no connection to the web).

The team is also faced with designing a sea channel for testing/validation of the tool to possibly creating a keel cooler based on the tools recommendation for one of the engines. The constraint would be adequately sizing a keel cooler for a vessel and not have the tool suggest a keel cooler length longer than the vessel itself. Due to the inherent inefficiencies of keel coolers, the tool needs to be able to process when to suggest different numbers of flows to improve cooling and ensure coolant velocity is below critical speeds.

Constraints:

- Budget of \$2,000
- Time
- Material Acquisition

3. Design and Analysis

3.1. Software Design

In order to design and write a successful program there are three primary considerations that the program designer must consider: Choosing the right programming language, identifying the user, and structuring the program correctly and effectively. In the design on the keel cooler optimization tool, careful consideration was given to these steps in order to maximize the tools effectiveness in servicing the applications engineers at Cummins Marine.

The choices for the programming language were based on a comprehensive list of the suitable languages that the members of the project group had exposure to. In order to select a language for consideration, the project group agreed upon options that they felt familiar with, had the capability to do mild computing, and had useful functions for implementation. The three final choices were reduced to C programming, MATLAB, and Java. A decision matrix was implemented in order to make the proper selection for the task. The group chose four main attributes and weighed them in order of importance to evaluate their ranks. The judging criteria was knowledge (the groups familiarity with the language), structure (does the program contain useful functions to structure a logic based selection system), aesthetics (user friendly interface), and relevance (how universal is the language). The attributes were ranked from 1 to 10 and were given a weighted multiplier with knowledge and structure given 60% and 20% weights respectively. These values were added up to produce a score. C programming ultimately prevailed to its superiority in knowledge, structure, and relevance. The decision matrix can be seen in *Table 1*.

Table 1. Decision Matrix

Program:	Knowledge	Structure	Aesthetics	Relevance	Total:
C	9	10	1	10	8.5
Java	2	7	8	8	4.2
Matlab	8	1	8	6	6.4

The second step of the design process was to identify the user in order to satisfy their needs in a program. After a coordinated sponsor meeting, the team was able to identify the primary users as application engineers as well as shipyard workers. After further inspection into the uses of the program, the design team concluded that the two primary uses of the optimization tool are for the validation and design of keel coolers. This led to the implementation of two main program modes, a verify mode and a design mode. The ‘verify’ user is one that has a premade keel cooler or keel cool design and wishes to simply evaluate whether their model will pass or fail. If the users design passes, the program would indicate so. If the users design fails, the program would allow the option of providing feedback in order to produce a passing design. An emphasis was placed on useful

feedback of the program, providing the user with only the information that they seek, optimizing the user interface. The design mode of the program offers an alternative approach for a user who is seeking the optimal size for their particular parameters. The user would provide constraints such as available material, hull size, amongst others and the program would evaluate the correct size (if possible) for a passing keel cooler design.

Engine Data		
Engine Model		from General Data Sheet
Engine Brake Horsepower [BHP]		from Performance Data Sheet
Engine Speed [rpm]		from Performance Data Sheet
Select a Cooling Circuit Type		from Performance Data Sheet
Total Circuit Heat Rejection [BTU/min]		from Performance Data Sheet
Coolant Flow to Keel Cooler [gpm]		from Performance Data Sheet
Engine Coolant Capacity [gallons]		from General Data Sheet
Coolant Type (50/50 glycol or Water/DCA)	Make a Selection	50/50 Glycol solution preferred
Maximum Sea Water Temperature [deg F]	85	Typical sea water temperature is between 75-85 deg. F
Design Speed [knots]		Typical sizing speeds are: 1) Tugs/Pushboats: 1-2 knots 2) Generator set: 0.1-1 knots
Keel Cooler Data		
Standard Channel Size	Make a Selection	C depth (inches) × Weight Per Unit Length (pound force per foot)
Channel Width [inches]		from standard steel channel tables
Channel Height [inches]		from standard steel channel tables
Web Thickness [inches]		from standard steel channel tables
Cross Sectional (Web) Area [sq. inches]		from standard steel channel tables
Coolant Velocity [ft/sec]		Best if kept between 2-8 ft/sec
Channel Material	Steel	
Total Installed Keel Cooler Length [feet]		Increase cooler length or number of flow paths until Pass/Fail criteria is met
Thermal conductivity "k" [BTU/hr-F-ft]	26.5	
Number of Flow Paths		
Results		
Actual KC Exterior Area [sq. feet]		
Calculated Exterior Area [sq. feet]		
Minimum Keel Cooler Length [feet]		
Minimum Expansion Tank Capacity [gallons]		from Installation Directions bulletin No. 3884744
Passing Criteria [Pass / Fail]		Increase cooler length or number of flow paths until Pass/Fail criteria is met

Figure 6: Current Specification Sheet

The program would use the same input parameters as the current validation tool, while adding the variability of adding design parameters for additional analysis. *Figure 6* shows the specification sheet for the current tool

Several considerations were given to the program structure. In order to minimize run time and maximize coding efficiency, the program was structured with a main function with conditionally accessed sub functions. The program will open up from the start and prompt the user to choose whether they would enter design or verify mode. The selection decisions are prompted by the use of switch statements that access sub-functions depending on the number that the user enters. If the user enters the analyze mode, the engine selection tool will ask the user for their engine selection. Depending on their response, the program will access separate functions which will store the parameters corresponding to their selection. Following the engine selection, the user will enter their coolant selection followed by their channel size dimensions. The program takes the information stored from these inputs and calculates the minimal cooler length and heat dissipation and compares it to the users input. If the user's cooler parameters correspond to a passing design, the program will display a message indicating passing and the program will terminate. If the user enters parameters that prompt a failing condition, the user will be informed as well as given the option to enter the programs design mode. The design mode will invoke a similar structure to the verification mode, with the exception that the user will be able to select additional parameters such as boat hull size that constrain their design. The program will evaluate the user's criteria and generate design parameters that will provide a passing condition. Because of the vast number of sub-functions the program employs, most of the variables will be redefined by the use of pointers. This reduces the number of variables and the memory required by the program minimizing run time. *Figure 7* shows a simplified flow chart for the Keel Cooler Optimization Tool.

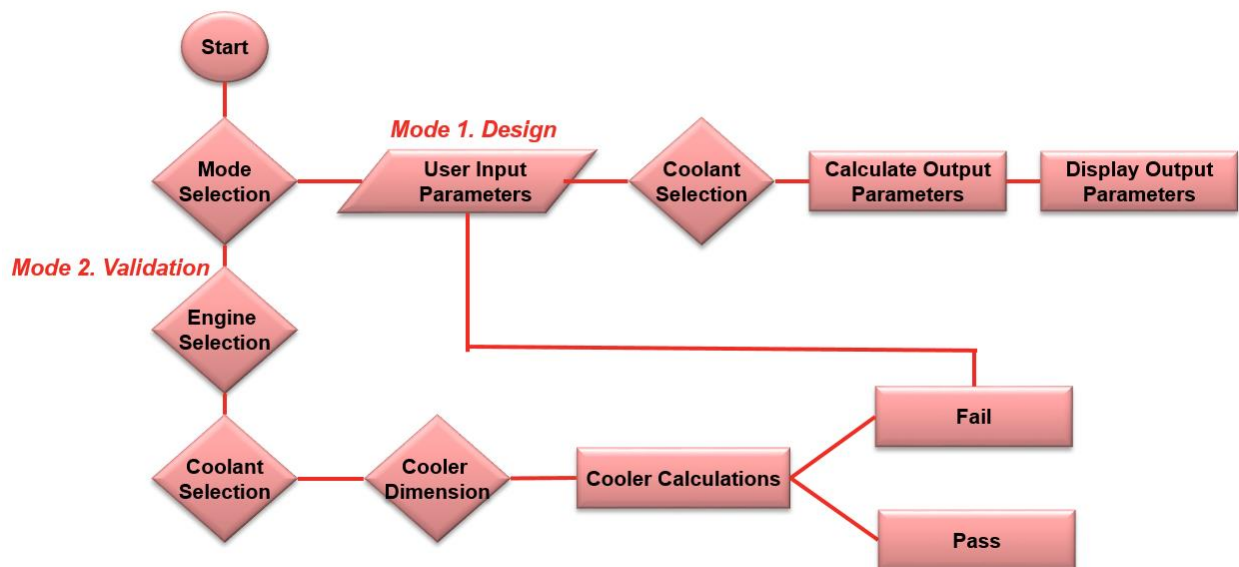

Figure 7: Flow Chart for Keel Cooler Optimization Tool

3.2 Hardware Design

Although the project is based on the creation of a software, the team found it useful to design and construct a testing apparatus in order to validate the predictive engineering written in the software. The team would have to create an apparatus which would simulate enough aspects if an installed engine/vessel package in order to ensure the most accuracy. Ideally, it would have helped the team to ultimately have a rig which consists of a piece of a keel, which would have required an immense water bath of flowing water. However, such simulation would have been impractical. The team then decided on a smaller design, one which only would involve a manufactured keel cooler.

The testing apparatus the team will create is illustrated and explained in *Figure 8*. The testing apparatus will consist of a 32 gallon drum. This will hold the water which will be run through the keel cooler which will be heated by a heating element to a constant 85 °F. The drum will also be equipped with a water pump rated at 20 gallons per minute. The water pump will cause the water to be carried through a pipe which will connect to the keel cooler the team will make. The keel cooler will be submerged in a water bath. The water inside the water bath where the keel cooler is located will not be flowing, since this will simulate the worst case operating scenario for a vessel, wide open throttle at 0 knots. This is common for vessels such as tugboats which push or pull other vessels and at times find themselves operating at open throttle but stationary in the water. The keel cooler will have an outlet pipe which will carry the used water to a rejection tank. This testing apparatus provides the team different locations to record temperatures in order to calculate thermal efficiency. Temperatures will be recorded through the use of thermocouples at the 32 gallon drum to ensure the temperature is held constant, the water bath where the keel cooler is located to see how the effects of the warm water carried through the keel cooler affect the surrounding simulated sea water, and the outlet water which will allow the team to calculate the thermal efficiency of the keel cooler.

In order to properly size a keel cooler which would work for the testing apparatus, the team took several design aspects into consideration. The created keel cooler could not be of an overwhelming size, since it needed to be practical in size for portability. The team had originally thought about designing a keel cooler for the QSK19 engine model, which would have caused the team to have to create a keel cooler that was too long for this purpose. The team then planned on creating a downsized version of the keel cooler for the QSK19, since it was believed the keel cooler would still represent the same cooling values. However, it was advised this was not done, since the thermodynamic properties do not size how the team thought it would. The team then shifted the brainstorming from utilizing the QSK19 engine to a 6B engine. It is a lot smaller engine, rated at 150 HP at 1800 RPM, but it allowed a more practical keel cooler testing apparatus. From the technical information available on the Cummins Marine website, utilizing the database for Application Engineers, the sea water pump performance for the 6B engine was obtained. Provided the engine size, the sea water pump performance would need to be able to operate within the range of 6 gallons per minute through 20 gallons per minute. This would allow the team to simulate the operation of a 6B engine operating through a range of 1500 RPM through 1900 RPM. The reason why it is beneficial for the team to operate the testing apparatus 100 RPM beyond the rated power for the engine, is when an engine is installed on a vessel, the operator is allowed to run the engine 100 RPM over the rated value, since the power band follows along the governor's curve. Therefore, the team selected a water pump which can operate to a 20 gallons per minute flow rate, but can

also be operated at a lower flow rate. Such ability would enable the team to test the keel cooler in more simulations than just one.

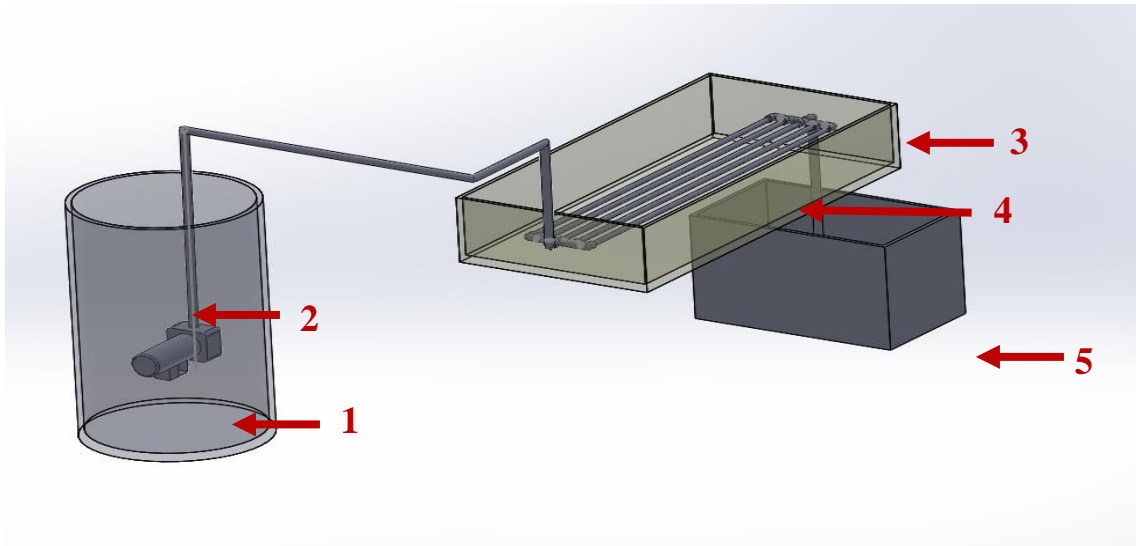

Figure 8: The keel cooler testing apparatus is illustrated above. The water pump (1) installed inside the 55 gallon drum (2) which will carry the heated water. The water bath (3) where the keel cooler (4) will be submerged while testing. The outlet water tank (5) will provide the team a means to measure outlet water temperatures to calculate the thermal efficiency of the keel cooler.

Basing the design on an actual engine allowed the team to compare the design to previous installations. The team wanted the keel cooler to be a multipurpose testing apparatus. The team wanted to be able to test the keel cooler as a single flow path and multiple flow path cooler. This presented itself to be another design challenge since the equations utilized to size the keel cooler take the number of flow paths into consideration. Therefore, the creation of a keel cooler which would be the same length, yet carry a different number of flow paths would not have the same thermal efficiencies. This was kept in mind when designing the keel cooler for the hardware testing apparatus, but it was said it would be adequate for the simulation the team was conducting since it would show a dramatic difference thermal efficiency of what a single flow path versus a multiple flow path keel cooler. Since the software will have the keel cooler validation and design aspect, it will help validate the engineering with real life results.

The keel cooler was designed to use aluminum tubes for the keel cooler. This material was chosen over steel since it is more cost effective to construct out of aluminum, and since the current tool is limited to evaluating steel keel coolers, the team felt it was best to carry out the experiment with the material which is being added to the program. The sizing of the pipe for the keel cooler as well as the required surface area of the cooler was calculated utilizing the equations 1 and 5 from before. It was calculated that a four foot long keel cooler would be adequate with 5 flow paths. Since the team will be able to simulate both a one path keel cooler and a 5 flow path keel cooler, the team will be able to compare the thermal efficiencies between the both as well as better understand what calls for a better designed keel cooler.

4 Updates and Schedule

4.1 Updates

Since the final report in the fall, the team has completed ordering most of the parts they will go into constructing the hardware that will be used to validate our program in later testing. These parts include the piping used to construct the manifolds on both ends of the keel cooler, the 55 gallon barrel to hold the water to be cooled and the heater to heat the water in the 55 gallon barrel. The parts that still need to be ordered are the thermocouples to measure temperatures in the inlet and outlets baths, and the cool water reservoir where heat will be dissipated. The cool water reservoir will be constructed either out of plywood or Plexiglas depending on what is available.

Our group has also begun more work on the program that will actually validate keel coolers and offer feedback on them. The work done includes; accumulating formulas, storing known information into the program, and collecting data sheets for motors that will need to be tested. The group is planning on having the first version of the program done in the beginning of February.

The group will continue to work on the program until the beta version is complete. It can then be tested against known information for motors that have already been implemented and are known to work correctly.

4.2 Schedule

In order to efficiently make use of the time the team has until the end of the semester, a Gantt chart *Figure 9*, created through the use of Microsoft Project has been prepared which lays out a breakdown of the work that needs to be completed. According to the chart, the team has accomplished the required tasks up to the present date and is moving forward on schedule. The team has just mapped out the framework for the code to our program which can now receive user inputs for the basic parameters involved in keel coolers, such as engine model type, c-channel specification, coolant type, etc. To make additional progress with the coding, the thermodynamic properties and relations associated with keel coolers must be organized and then evaluated for accuracy. The team is in the process of arranging a meeting with our technical advisor Dr. Van Sciver for guidance in this step. During this meeting the team will also discuss plans for our testing apparatus. Once the program is “fleshed out” it can be debugged and to be tested by the sea channel the team will make. With the creation of the sea channel the team will be able to simulate the cooling system and test/validate the tool. The creation of the sea channel would allow the team to collect data from the simulation, such as flow rates, in order to ensure proper calibration of the tool. Once the team has created a tool which can test a cooling system and recommend an optimized keel cooler for the engine/vessel installation, the sponsor has agreed to remain in contact with the boat builder near Tallahassee, Florida to test the tool on a current keel cooled installation.

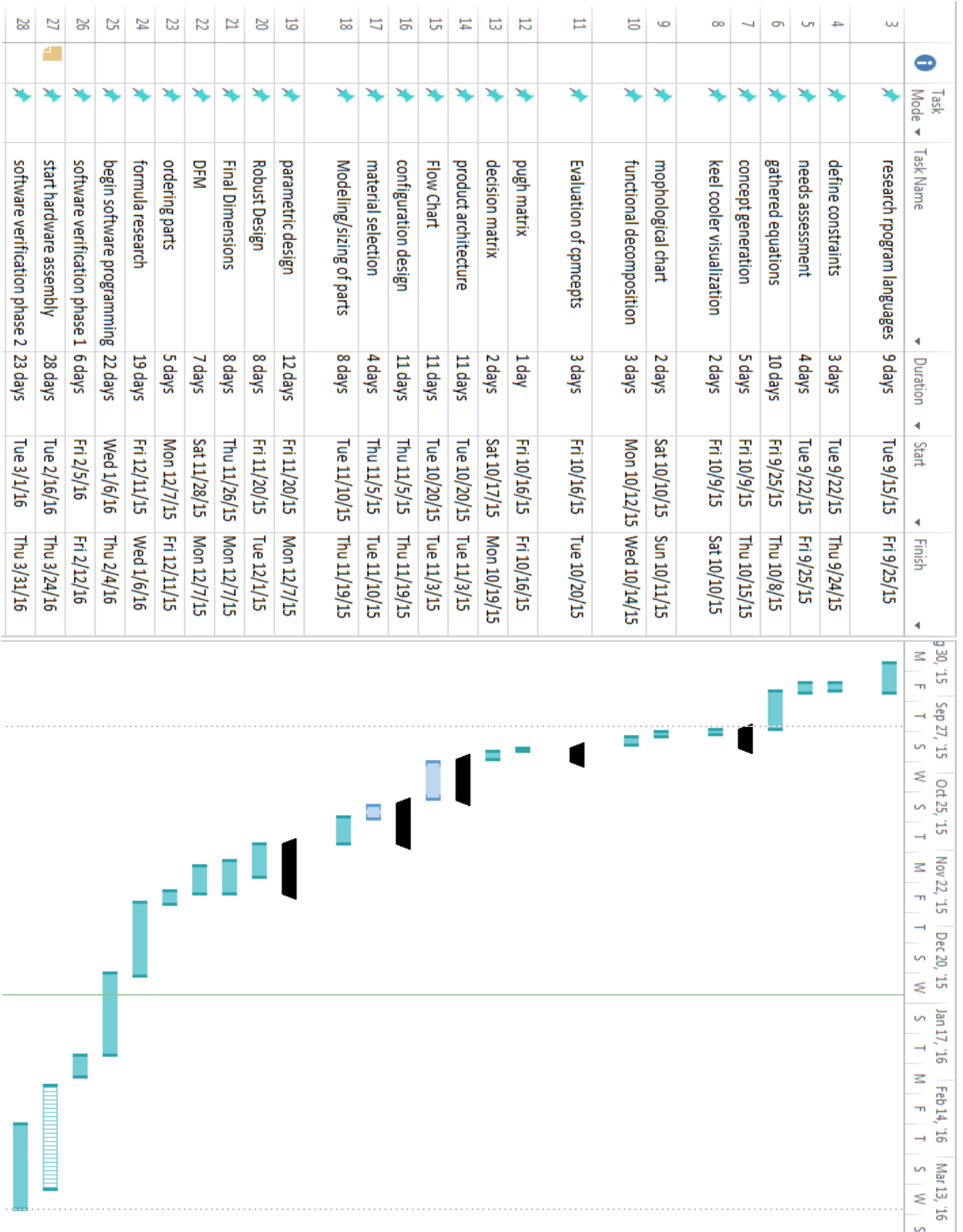

Figure 9: Updated Gantt chart for spring semester

5. Conclusion

The Marine Keel Cooler Optimization tool hopes to meet the needs of Cummins Marine in providing a tool that is up to date, user-friendly, and reliable. The current tool utilized by Cummins Marine was commissioned in the early 1980's, is limited in its ease of use, and only provides a pass/fail output for the user. Cummins Marine is in need of an updated tool which not only validates a proposed design (pass/fail), but can also provide additional design requirements and specifications that will ensure proper cooling performance in the application environment. The team is tasked with writing a program that will utilize these features and provide accurate results. The group has been (and will continue throughout the duration of the project) researching general information and implementing the knowledge from thermodynamics, fluid mechanics, and heat transfer in order to successfully achieve the project goal. In addition to writing the program, the team will build a testing apparatus that will be used to model and evaluate the differences in performance for various design configurations, i.e. number of flow paths, types of materials, orientation, etc., and can also be used to verify the accuracy of the program. The parts for the hardware side that are hardest to obtain have been ordered, such as the pump, heating tank/element, and thermocouples. Since the main script (framework) of the program has already been written, it is only a matter of ensuring the proper engineering principles are employed when fleshing out the rest of the program. This is a crucial step because if the tool does not provide correct data to the end user, the design could cause catastrophic engine failure once it is implemented on a production vessel. Once the program has been coded, it can be verified for accuracy by using both data obtained from our testing rig and with data provided by Cummins regarding successful systems that are currently in use. The work left to be done for the remainder of the project consists of ordering the more common parts required for the hardware, building the hardware once all of the parts are in, implementing the engineering formulas into the program, and checking/modifying the program to guarantee accurate and reliable results. Following the customer requirements defined by the Sponsor the team expects the keel cooler optimization tool will surpass current expectations while meeting all of the customer needs.

References

1. Shaw, Courtney. "Cummins Marine Propulsion." *Cummins Marine*. Web. 23 Sept. 2015. <<http://marine.cummins.com/>>.
2. "Marine Keel Coolers for Heat Dissipation." *Marine Keel Coolers for Heat Dissipation*. Web. 23 Sept. 2015.
3. *Cummins Keel Cooler Sizing Tool*. Computer software. Vers. 2.0. Cummins, n.d.Private Web. 23 Sept. 2015.
4. "Code of Ethics." *Code of Ethics*. N.p., n.d. Web. 06 Dec. 2015.

Biography

Stanko Gutalj – *Project Leader*

Stanko Gutalj is currently a Systems Engineer at Siemens Building Technologies as well as a research assistant at the Florida Center for Advanced Aero-Propulsion. Stanko is currently involved in an ongoing research investigation on the control of trailing edge vortices under the guidance of Dr. Louis Cattafesta and Adam Edstrand. His contributions include the design of a structural support column for an NACA0012 airfoil and an automated turntable system for precise angular control for wind tunnel testing.

Melissa Allende – *Technical Liaison*

Melissa Allende is currently her second Co-Op working alongside the Marine Application Engineers at Cummins Inc., while completing her senior year in Mechanical Engineering. Melissa was first introduced to marine diesel engines at Caterpillar Inc. where she as an intern for Caterpillar Inc. alongside the Marine Product Health Engineers. She would later complete her first six month Co-Op with Cummins Inc.

Grady Beasley – *Web Based Technician*

Grady is currently a senior Mechanical Engineering student at the FSU-FAMU College of Engineering. He is on track to graduate in the spring of 2016 with a specialization in aeronautics and a minor in mathematics. Outside of his studies, Grady spends his time doing various hands-on projects, working on anything with a motor, and playing the drums. After graduation he plans to move to the west coast to capitalize on mechanical engineering knowledge and explore entrepreneurial prospects.

Jacob Ross – *Financial Advisor*

Jacob Ross is a senior in Mechanical Engineering at Florida State University. During his time studying engineering, he became more interested in aerodynamics and applications of aerodynamics in modern flight. Thirsting for more knowledge, he began training to become a pilot. While continuing his pilot's training, Jacob also works for Professors at Florida State University as a teaching assistant, after graduation plans to finish his master's degree in mechanical engineering and enter the Aerospace Industry.

James Haga – *Administrative Assistant*

Herman "James" Haga IV was born in Fort Valley, GA in 1993 where he lived on a dairy farm for seven years before moving to St. Augustine, FL in 2000. Now James is a senior in mechanical engineering at Florida State University and plans to graduate in the spring of 2016 with his BS in mechanical engineering. James has held one internship at Northrop Grumman as a liaison engineer in the summer of 2013. While in the internship, James gained knowledge of E-2D and F-5 aircraft.